

Trailed Mower Conditioners



www.KuhnNorthAmerica.com

FC TL – Side Pull FC TC – Center Pivot



Invest in Quality[®]

TRAILED MOWER CONDITIONERS FC TL Series / FC TC Series

MAXIMUM PRODUCTIVITY AND PERFORMANCE

SIMPLE, EASY MAINTENANCE

Less time spent on routine maintenance means more time in the field for maximum productivity. With an efficient design and high-quality seals, daily greasing has been eliminated. The gearbox drive removes the hassle of regular belt adjustments. Cutterbar oil changes are a thing of the past with the lubed-for-life Optidisc® cutterbar and the Fast-Fit system makes blade changes quick and easy!

HIGH-CAPACITY, PRECISE CONDITIONING

Fast, consistent drydown is the key to high-quality forage. Wide rotor, finger-style conditioning on the FC TL and TC models increases crop-on-crop rubbing to strip off the waxy cuticle helping the stems dry at the same rate as the leaves. Two different roller-style conditioners are also available on all models. The Diamond Block® rubber conditioning rollers crimp the crop every 3 to 6 inches for fast drydown. The DoubleCrimp™ steel roller conditioner features a unique square-tooth shape that crimps the crop constantly every 1.5"-2" regardless of crop volume.

MULTIPLE WINDROW ADJUSTMENTS

From narrow windrows to wide swaths, these models offer the broadest range of windrowing options to best match different harvesting practices and field conditions.

TRAILED MOWER CONDITIONERS

FC TL / FC TC

in brief

Models	Working Width	Swath Width	Horsepower Requirement
FC 2860 TL	8'10"	3' – 6'8"	67 hp
FC 3160 TL	10'2"	3' – 7'8"	80 hp
FC 3560 TL	11'6"	3' – 8'8"	93 hp
FC 3160 TC	10'2"	2'11" – 9'2"	80 hp
FC 3560 TC	11'6"	3'7" – 10'4"	93 hp
FC 4060 TC	13'	3'7" – 11'9"	107 hp



FC TL / FC TC

PRECISE ADJUSTABILITY

FINGER MODELS

The DigiDry™ finger conditioner provides consistent drying of grass and legume crops in various conditions with little maintenance. Wide rotor, finger-style conditioning increases crop-on-crop rubbing to strip off the waxy cuticle helping the stems dry at the same rate as the leaves. The built-in breakback feature normally protects against damage from rocks and other foreign materials.

SIMPLE SPEED CHANGES

The simple 2-speed selector eliminates the need to swap sheaves and belts to change rotor speeds. A quick switch of the lever position slows the conditioning rotor to 760 RPM for delicate legume crops or speeds it up to 1000 RPM for tough grasses.

MULTIPLE HOOD POSITIONS

Quickly and easily select from one of five hood positions to fine-tune the intensity of crop conditioning. Depending on the type of crop and volume, periodic adjustments may be needed to ensure desired conditioning.



ROLLER MODELS

Diamond Block® conditioning rollers stand out from the competition as the only rubber roller set designed exclusively for a disc mower. The horizontal staggered diamond pattern gives more points for the crop to be crimped as it flows off the disc at an angle. Adjustment of the roll pressure and roll gap is simple and can be done quickly in the field.

The DoubleCrimp™ steel roller design provides consistent crimping and even feeding of thicker crops and extended life in difficult and abrasive conditions. The steel construction normally allows for a longer wearing life yet allows for thorough conditioning of more delicate crops like alfalfa. Adjustment of the roll pressure and roll gap is simple and can be done quickly in the field.



A CLEAN & CONSISTENT CUT

The Optidisc® Cutterbar: Lubed-for-Life

The Optidisc cutterbar requires no break-in oil change or scheduled maintenance for the life of the machine. It has a flat profile allowing the crop to move through quickly for smooth flow even in heavy, difficult conditions.

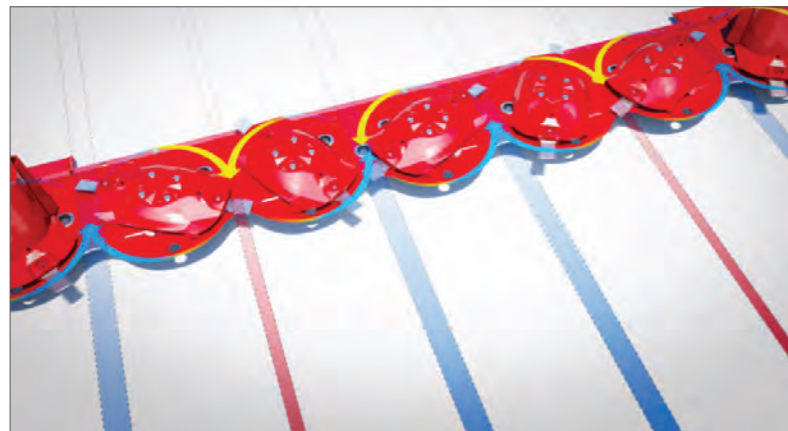

OPTIDISC CROP CONTROL

The innovative design offers exclusive differential disc spacing. Narrower spacing at **diverging discs (red)** provide greater knife overlap for cleaner cutting. Wider spacing at **converging discs (blue)** provides greater capacity and higher throughput.



ULTIMATE PROTECTION

Externally removable Protectadrive® disc bearing stations provide maximum reliability and quick service. They normally protect the cutterbar from damage if a major obstacle is struck in the field.



OUTSTANDING CROP LIFT

The cutting discs and end cones provide high crop lift, allowing cut materials to quickly leave the cutterbar and enter the conditioner, especially in thick crop conditions.



FAST-FIT KNIVES

Fast-Fit allows quick changing of knives with the use of a simple tool, yet still provides the optimum cut quality and knife life seen with the standard system. With Fast-Fit, you can achieve up to 50% time savings.

TIGHT TURNS AND CLEAN, SQUARE CORNERS



RUGGED BUILD AND SIMPLE MAINTENANCE



GYRODINE® SWIVEL HITCH

The heavy-duty Gyrodine gearbox is designed to withstand the most severe pull-through force from the hitch to the machine. The swivel design allows turns in excess of 90° while keeping the PTO driveline straight. This design allows extremely tight turns for clean, square corners while minimizing PTO vibration and wear.



QUICK HITCH COMPATIBLE 2-POINT

The CAT 2/3N quick hitch compatible 2-point hitch provides a fully controlled connection and allows easy adjustment to maintain a level PTO. It also provides more ground clearance for previously mowed crop to pass through. Connecting arms pivot during hookup for easy alignment. All connecting quick hitches must meet standard ASABE specifications.



SIMPLE DRAWBAR HITCH

The drawbar hitch is easy to hook up and the heavy-duty build provides dependability and long life. The built-in swivel allows movement in three dimensions to easily adapt to uneven field conditions.



HIGH-STRENGTH STEEL FRAME

The high-strength steel frame provides sturdy support for the heavy-duty cutterbar and conditioner. Pound-for-pound this material provides 50% greater tensile strength than the mild steel found on competitive units. This lightweight, yet high-strength design reduces horsepower requirements and fuel consumption.

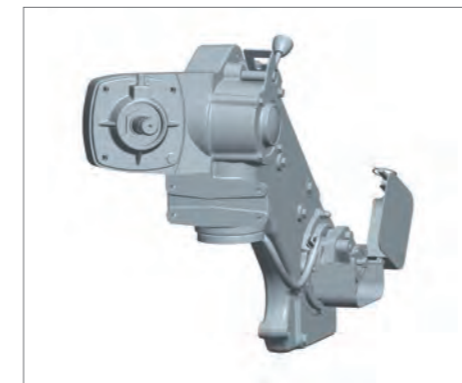

HEAVY-DUTY MAIN GEARBOX

The main gearbox is the core of the unit, specially built by Kuhn to efficiently and reliably transfer power to the cutterbar and finger conditioner or rollers. The direct drive eliminates periodic checks on belt tightness and wear.

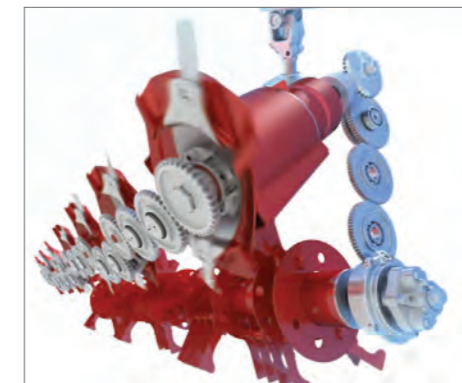

BUILT-IN ROTOR PROTECTION

To help prevent damage to the gearbox in the unlikely event of an overload or ingestion of a large foreign object, the shear bolt hub allows the operator to clear the obstruction from the conditioner, quickly rotate the inner hub into position, install the new shear bolt and return to mowing. Machines with roller conditioners use a specially designed gearbox for direct drive simplicity and reliability. Shear protection on these machines is similar and can be quickly replaced in-field.



MAINTENANCE-FREE DRIVE SHAFT

Unlike competitive models that require daily greasing, the drive shaft to the cutterbar uses maintenance-free U-joints. These joints reduce overall maintenance and eliminate excessive wear from improper maintenance.



TRAILED MOWER CONDITIONERS FC TL Series

REDESIGNED AND REDEFINED

Cutting-Edge Mower Conditioners

The new FC TL trailed, side-pull mower conditioners offer fast, clean mowing of heavy grasses and delicate forage crops combined with quick drydown from consistent, effective conditioning. Windrow widths can vary from narrow to a wide swath to adapt to different harvesting practices and field conditions. These machines are the most advanced side-pull mower conditioners in the industry with the operational simplicity you want and the performance you demand for the maximum return on your investment.



CONSTANT FLOAT® SUSPENSION

The header is suspended on each side by a long, large-diameter spring that provides a constant range of flotation. The floating head lifts up and back, and oscillates from side to side, to closely follow ground contours and conform to irregular terrain. This reduces the amount of missed crop in the field and helps keep dirt out of the harvested crop.



PRO-ACTIVE LIFT®

This maintenance-free system allows the machine to quickly adapt to abrupt changes in terrain or when an obstruction is encountered in the field. The cutting head is able to move up and back simultaneously, dissipating the force of any impact and providing space to clear the obstacle. This unique design reduces scalping to preserve crop stubble and helps protect the machine from potential damage. A slotted linkage on each side provides guidance for the header and eliminates the need to run the hydraulics in the float position.



EASY CUTTING HEIGHT ADJUSTMENT

The header tilt turnbuckle provides a single point for cutting height adjustment. This allows fast, easy changing of the cutting height without the need for any tools.

KEEP YOUR OPTIONS OPEN

Simple Windrow Adjustment

Windrow widths can be adjusted from 3' up to a wide swath. When creating a windrow, the swathboard located at the rear of the conditioning system acts as a guide and directs the crop stream higher up on the fixed forming shields, resulting in a progressively narrower windrow.



EIGHT SET POSITIONS

The single-point adjustment handle offers eight set windrow width positions to match different harvesting practices and field conditions. Additional fine-tuning is possible by rotating the adjustment plate. Positions closer to the positive symbol mean wider swaths and positions closer to the negative symbol indicate that the swath board is up and will result in progressively narrower windrows.



WIDE SWATHING

Independent study results from forage agronomists are consistent: In normal conditions, wide swathing to at least 70% of cut width greatly reduces drying time. Faster drying provides greater flexibility to avoid bad weather, helping retain higher quality feed.

Kuhn is the only full-line hay tool manufacturer offering standard-equipped mower conditioners that provide greater than 70% wide swathing. Without additional bolt-on parts or expensive optional equipment commonly required on competitive models, Kuhn FC TL machines will produce swaths up to 75% of cut width.



TRAILED MOWER CONDITIONERS FC TC Series

FAST MOWING, FAST DRYDOWN

Superior Productivity

When productivity matters most, the FC TC trailed, center-pivot mower conditioners are the choice for you! These machines provide fast mowing and fast, consistent drydown for maximum efficiency and a high-quality crop. With the broadest range of windrow width settings in the industry, they offer an unmatched ability to adapt to different harvest practices and field conditions.

ADVANCED SUSPENSION

The torsion bar suspension system provides exceptional flotation to precisely follow ground contours. The torsional resistance can be easily fine-tuned to match the header ground pressure to different field conditions and operating speeds. A built-in slotted linkage eliminates the need to run the hydraulics in the float position.

ARTICULATED CUTTING HEAD

The articulated head flexes up and down to closely follow ground contours. At the same time the rear of the unit is linked to the main frame keeping crop dispersal at a constant height relative to the ground. This allows more consistent crop flow and better shaped windrows or swaths.



ADJUSTABLE FORMING SHIELDS

The adjustable forming shields allow the windrow width to be varied to match different harvest practices and weather conditions. Preset indications allow you to precisely match the setting on both sides. When not in use the shields are easily removed and placed in the storage position on the tongue.



REAR HOOD ADJUSTMENT

The rear hood includes the windrow formation side and a side with spreading fins for use in wide spreading. The hood can be angled up and down in the windrow position to form neater windrows. It can be easily flipped to the opposite side on wide spreading models. Both sides have tilt adjustability to either stand crop up for windier conditions or lay crop flat for sunnier conditions.



WIDE SPREADING

The wider the crop is spread, the more surface area there is exposed to the sun for faster drying. The FC TC allows wide spreading to over 90% of cut width for accelerated drydown. The nine vanes on the rear hood automatically pivot to keep cut crop from being thrown into uncut areas.

Standard on finger conditioner models and optional on roller models.

OPTIONAL EQUIPMENT

FC TL Series / FC TC Series



1000 RPM DRIVE

Standard on FC 3560 and 4060 TC

An optional 1000 RPM PTO offers flexibility for the customer to run the mower with a larger tractor and provides dependable operation in varied conditions.



HIGH-LIFT SKID SHOES

For customers requiring a higher cut height for certain crops or when cutting in rocky conditions. The skids are adjustable for cutting between 2.1" - 6".

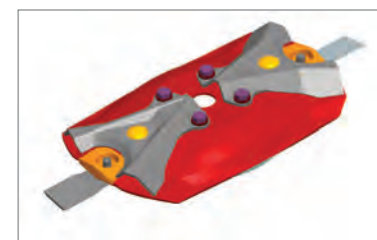

LIFTER DISCS

Recommended only for sorghum or other hard feeding crops.

FC TL Series



CV SECONDARY PTO SHAFT

For flexibility to steer around obstacles in the field with the mowers' hydraulic swing cylinder, or to mow directly behind the tractor without PTO chatter, a secondary PTO shaft equipped with a constant velocity joint can be factory ordered or field installed. This option is highly recommended for operation with tractors that have narrow or typical row crop spaced tires.



PLASTIC ROCK GUARD

A rock guard can be mounted on the underside of the front hood for added protection in rocky conditions.

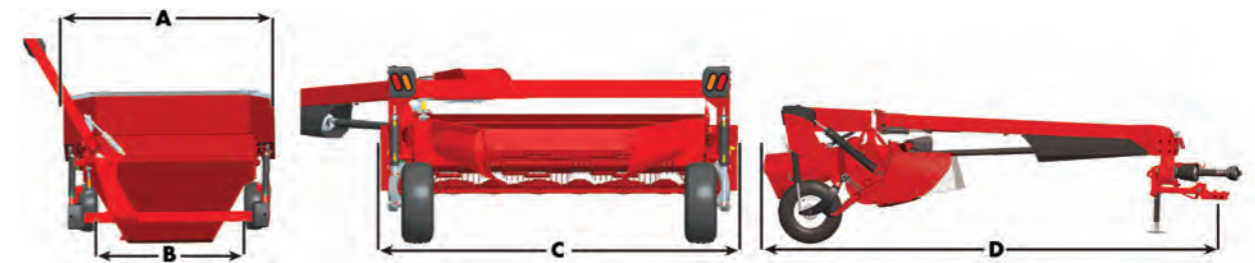

Model Specifications

SIDE-PULL MODELS	FC 2860			FC 3160			FC 3560		
	TLD	TLR	TLS	TLD	TLR	TLS	TLD	TLR	TLS
DIMENSIONS									
A - Width of Cut	8'10"/2.7 m			10'2"/3.1 m			11'6"/3.5 m		
B - Minimum Swath Width	3'/0.9 m			3'/0.9 m			3'/0.9 m		
Maximum Swath Width	6'8"/2 m			7'8"/2.3 m			8'8"/2.6 m		
C - Transport Width	8'10"/2.7 m			10'4"/3.1 m			11'8"/3.6 m		
D - Transport Length	18'4"/5.6 m			19'3"/5.9 m			19'3"/5.9 m		
SPECIFICATIONS									
Hitch Type	Drawbar or 2-Point Cat 2/3N								
Conditioning System	Finger	Rubber Roller	Steel Roller	Finger	Rubber Roller	Steel Roller	Finger	Rubber Roller	Steel Roller
Tire Size	9.5L-15SL (12.5L-15SL Optional)						12.5L-15SL		
Number of Discs	6			7			8		
PTO Speed	540 (1000 Optional)								
Disc Rotational Speed	2815 RPM								
Cutting Height	1.2"-3.2" / 3.0-8.1 cm (with optional high skids 2.1"-6"/5.3-15.2 cm)								
Conditioning Speed (RPM)	760 & 1000	770		760 & 1000	770		760 & 1000	770	
Rotor Width	72"/1.8 m	-		89"/2.3 m	-		105"/2.7 m	-	
Roll Width	-	78"/2.0 m		-	95"/2.4 m		-	111"/2.8 m	
Max Swath to Cut %	75%								
Suspension Travel	+10" to -5.75"/+25.4 to -14.6 cm								
Machine Weight	3,240 lbs/ 1,470 kg	3,500 lbs/ 1,588 kg	3,460 lbs/ 1,569 kg	3,860 lbs/ 1,751 kg	4,160 lbs/ 1,887 kg	4,115 lbs/ 1,867 kg	4,300 lbs/ 1,950 kg	4,600 lbs/ 2,087 kg	4,550 lbs/ 2,064 kg
OPERATING INFORMATION									
Hydraulic Requirement	Two Double-Acting								
Minimum Power Requirement	67 hp/50 kW			80 hp/60 kW			93 hp/69 kW		

CENTER-PIVOT MODELS	FC 3160			FC 3560			FC 4060		
	TCD	TCR	TCS	TCD	TCR	TCS	TCD	TCR	TCS
DIMENSIONS									
A - Width of Cut	10'2"/3.1 m			11'6"/3.5 m			13'/4.0 m		
B - Minimum Swath Width	2'11"/0.9 m			3'7"/1.1 m			3'7"/1.1 m		
Maximum Swath Width	7'7"/2.3 m			8'10"/2.7 m			8'10"/2.7 m		
Maximum Wide Spreading	9'2"/2.8 m			10'4"/3.1 m			11'9"/3.6		
C - Transport Width	10'4"/3.1 m			11'8"/3.6 m			13'3"/4.0		
D - Transport Length	22'1"/6.7 m			22'1"/6.7 m			23'11"/7.3 m		
SPECIFICATIONS									
Hitch Type	Drawbar or 2-Point Cat 2/3N								
Conditioning System	Finger	Rubber Roller	Steel Roller	Finger	Rubber Roller	Steel Roller	Finger	Rubber Roller	Steel Roller
Tire Size	12.5L - 15SL (31 x 13.5L-15 Optional)								
Number of Discs	7			8			9		
PTO Speed	540 (1000 Optional)						1000		
Disc Rotational Speed	2815 RPM								
Cutting Height	1.2"-3.2" / 3.0-8.1 cm (with optional high skids 2.1"-6"/5.3-15.2 cm)								
Condition Speed (RPM)	780 & 1000	770		780 & 1000	770		780 & 1000	770	
Rotor Width	97" / 2.5 m	-		113" / 2.9 m	-		113" / 2.9 m	-	
Roll Width	-	95" / 2.4 m		-	111" / 2.8 m		-	111" / 2.8 m	
Max Swath to Cut %	Up to 90%+ (Roller models require wide spreading kit)								
Suspension Travel	+10" to -5.75"/+25.4 to -14.6 cm								
Machine Weight	5,213 lbs/ 2,365 kg	5,456 lbs/ 2,475 kg	5,368 lbs/ 2,435 kg	5,544 lbs/ 2,515 kg	5,710 lbs/ 2,690 kg	5,610 lbs/ 2,545 kg	5,853 lbs/ 2,655 kg	5,997 lbs/ 2,720 kg	5,897 lbs/ 2,675 kg
OPERATING INFORMATION									
Hydraulic Requirement	Two Double-Acting								
Minimum Power Requirement	80 hp/60 kW			93 hp/69 kW			107 hp/80 kW		

COMPLEMENTARY PRODUCTS

OLD WORLD KNOW-HOW, NEW WORLD INGENUITY

TL and TC mower conditioners were jointly developed and tested in the factories and fields of North America and Europe. This combination of talents and diversity of experiences allows Kuhn to deliver the most advanced and proven mower conditioners on the market!

UNDERSTANDING THE MODEL NUMBERS

As you can see from the example to the right, the Kuhn model numbers are designed to be completely understandable to you and your dealer so there is no confusion when purchasing and servicing machines. This is part of Kuhn's commitment to being there for you, from start to finish.

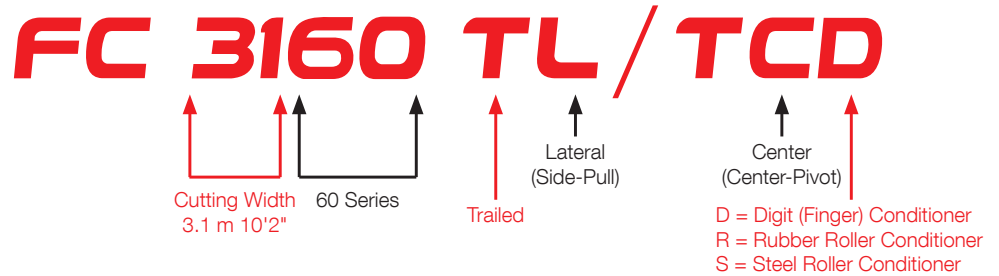

1. Tedders
2. Wheel Rakes
3. Rotary Rakes
4. Mergers
5. Balers
6. TMR Mixers

For more information about your nearest Kuhn dealer and other Kuhn products, visit our website at

www.KuhnNorthAmerica.com



Visit our YouTube channel to watch our latest product videos.

KUHN NORTH AMERICA, INC.

Corporate Headquarters
1501 West Seventh Avenue - Brodhead, WI 53520
Phone: (608) 897-2131 Fax: (608) 897-2561

 www.KuhnNorthAmerica.com	Your Kuhn dealer
---	------------------

Information given in this document is only for informational purposes and is non-contractual. Our machines are in compliance with North American safety standards. In our literature, and for improved illustration of certain details, some safety devices may not be in operating position. When operating these machines, these devices must be operated in accordance with the requirements indicated in the operator's manuals and assembly manuals. We reserve the right to change any designs, specifications or materials listed without further notice. Machines and equipment in this document can be covered by at least one patent and/or registered design. Trademarks cited in this document may be registered in one or several countries.

Find us on

